

KANSO

INTERIOR
C O M P A N Y
— By Square Yards —

3 Shutter Shoes Rack

Assembly Instructions



TIPS BEFORE YOU START

1. Please check that all parts are present before you start the assembly of your furniture.
2. For ease and speed of assembly, we recommend that before you commence each step of the assembly, that you identify all the parts required for that step.
3. For larger items, please ensure that you have sufficient space and people to assemble your product safely.
4. We recommend that, where possible, all items are assembled near to the area in which they will be placed in use, to avoid moving the product unnecessarily once assembled.
5. For the protection of your furniture, we recommend that the product is placed on a protected surface during assembly to prevent any damage.
6. During assembly please take care not to over-tighten any fittings, as this may damage the product. Do not use power tools.
7. Always place the product on a flat, steady and stable surface.
8. Do not stand on the product. Do not use the product as a stepladder.
9. This product is intended for indoor, household use only as it is a non-industrial product.
10. Please use caution and care when lifting the product to avoid personal injury and/or product damage.

CARE AND MAINTENANCE OF YOUR FURNITURE

1. Please periodically check all fittings and re-tighten as necessary.
2. To clean your item, please use a damp cloth and wipe clean.
3. Never allow any kind of liquid to remain on your furniture. Absorption can cause wood to warp or finishes to de-laminate.
4. Please do not place hot items (e.g. hot drinks) directly on to the surface.
5. Please do not drag and pull your furniture.



ASSEMBLY REQUIREMENTS

1. Equipment: Philips head screwdriver
2. 2 x adult required
3. 1m x 1m assembly space required
4. 1 Hour assembly time approx.



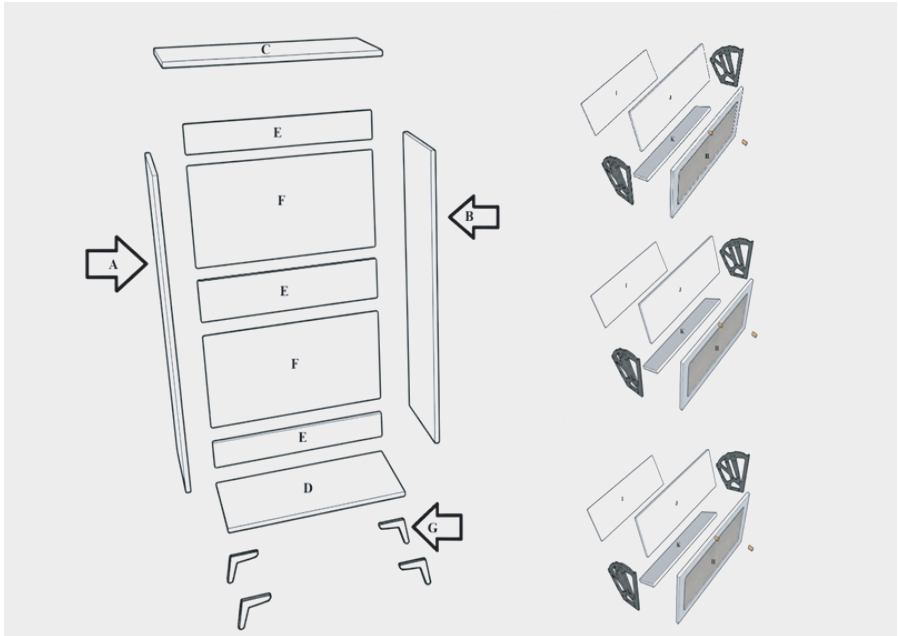











Assembly Instructions for Kanso 3 Shutter Shoes Rack

Parts List

Parts	Description	Qty	Notes
A	Left Side Panel	1	Vertical side wall
B	Right Side Panel	1	Vertical side wall
C	Top Panel	1	Top horizontal cover
D	Bottom Panel	1	Base panel
E	Back Panel / Horizontal Support	3	Fixed behind each shelf for structural support
F	Shelf Panel	2	Main shelf panels
G	Corner Brackets	4	Used to reinforce joints at bottom corners
H	Basket Frame	3	Tilt basket outer frame
I	Front Panel (Small)	3	Upper front panel for basket
J	Front Panel (Large)	3	Lower front panel for basket
K	Basket Base Panel	3	Bottom panel inside basket

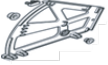
HARDWARE LIST

Sr. No.	Item	Quantity	Purpose / Where Used	Image
A	Screws-16 mm	16 pcs	For fixing buffers and fittings	
B	Screws - 19 mm	42 pcs	For fixing panels and legs	
C	Quick Fix Screws (for Minifix)	14 pcs	For joining the boards	
D	Cam Locks & Cap (for Minifix)	14 pcs	For securing the boards	
E	Screw Driver	1 Nos	For Installation	
F	Wooden Dowels	20 pcs	For board alignment and joining	
G	T-Type Leg	4 pcs	For bottom support (Part F)	
H	Knob	3 pcs	For opening the doors	
I	Shoes Rack Fitting	3 pcs	For internal drawer mechanism	
J	Cabinet Connector	6 pcs	For connecting frame parts	

Step 1: Assemble Cabinet Base

1. Place Left Side Panel (A) and Right-Side Panel (B) upright.
2. Position Bottom Panel (D) between panels A and B.
3. Secure from the bottom using screws.
4. Ensure both side panels are straight and aligned.

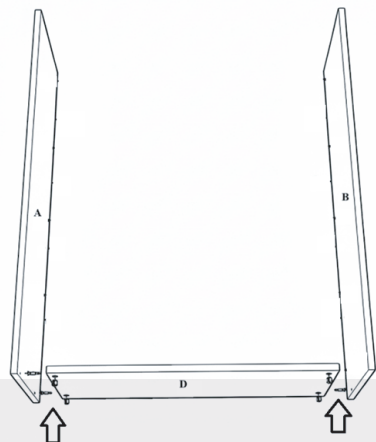

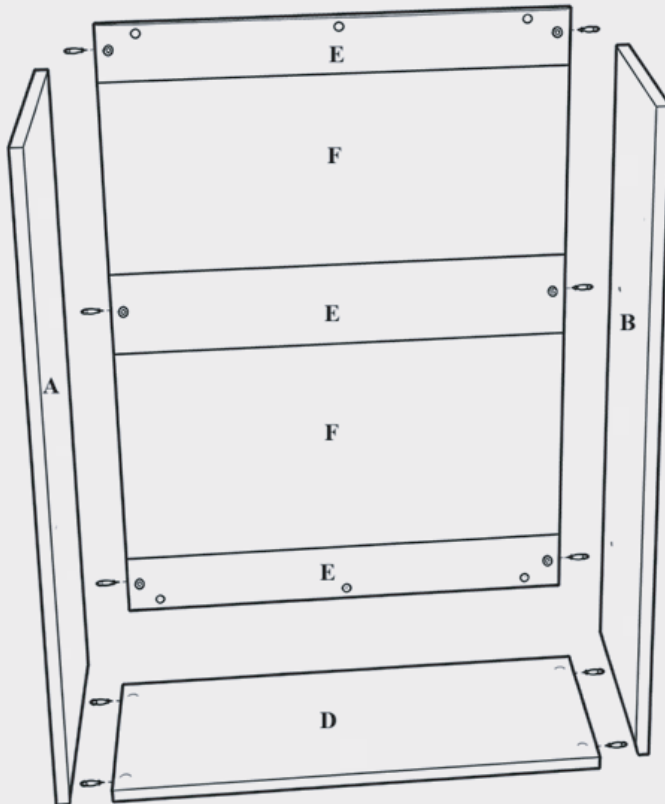

Step 2: Fix Back Supports and Shelves

1. Attach Back Panel / Support (E) at the top.
2. Fix Shelf Panel (F) below it.
3. Repeat the sequence: E → F → E → F → E.
4. Tighten all screws evenly on both sides.

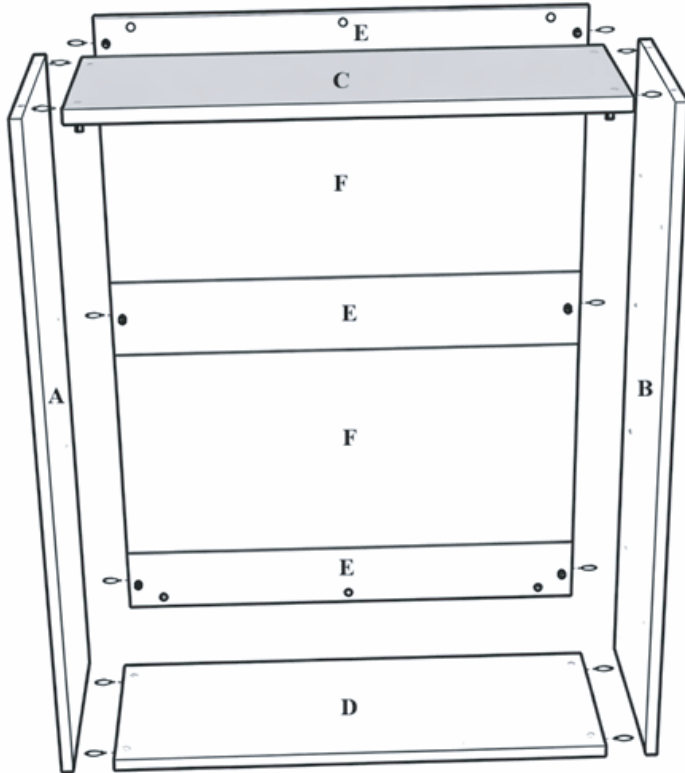

3

4

Step 3: Install Top Panel

1. Place Top Panel (C) on the upper support (E).
2. Align all holes properly.
3. Secure using screws from both sides.

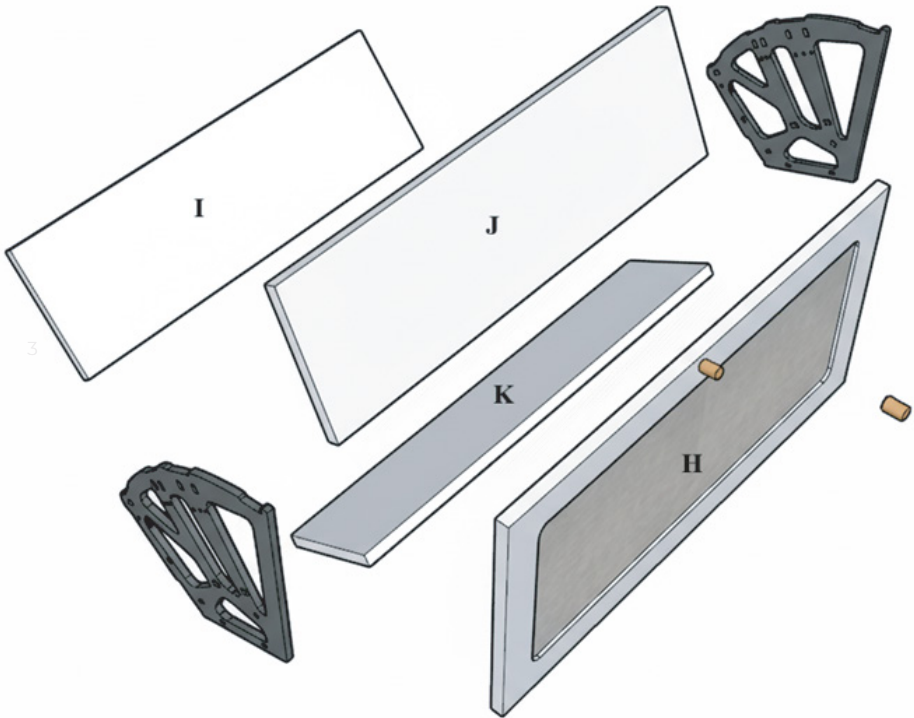

4

Step 4: Prepare Basket Assembly

1. Place Basket Frame (H) on a flat surface.
2. Insert Basket Base Panel (K) inside the frame.
3. Keep parts aligned.

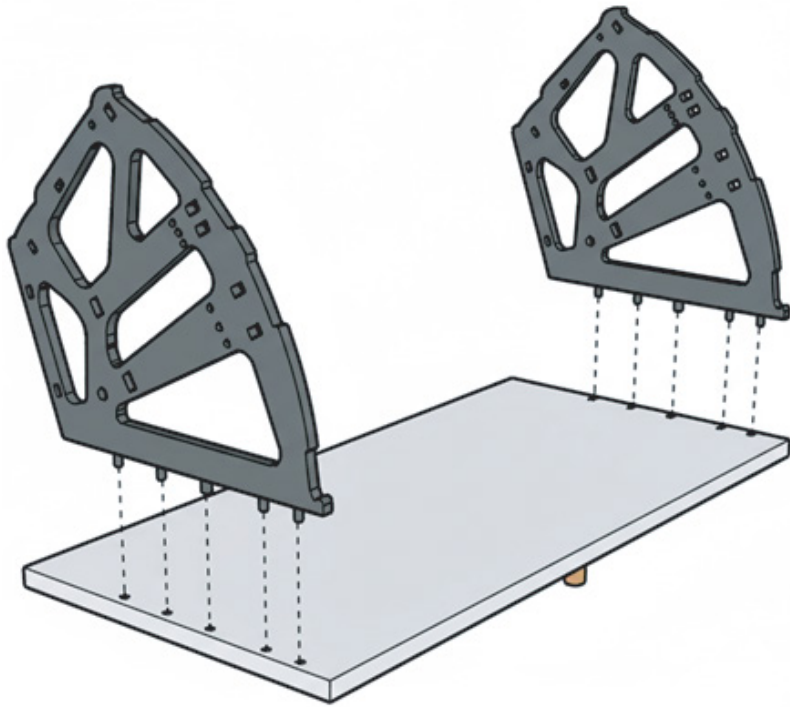

Step 5: Fit Basket Side Brackets (Push-Fit)

1. Align the basket side brackets with the holes on Basket Frame (H).
2. Press firmly until brackets are fully seated.
3. No screws are required in this step.

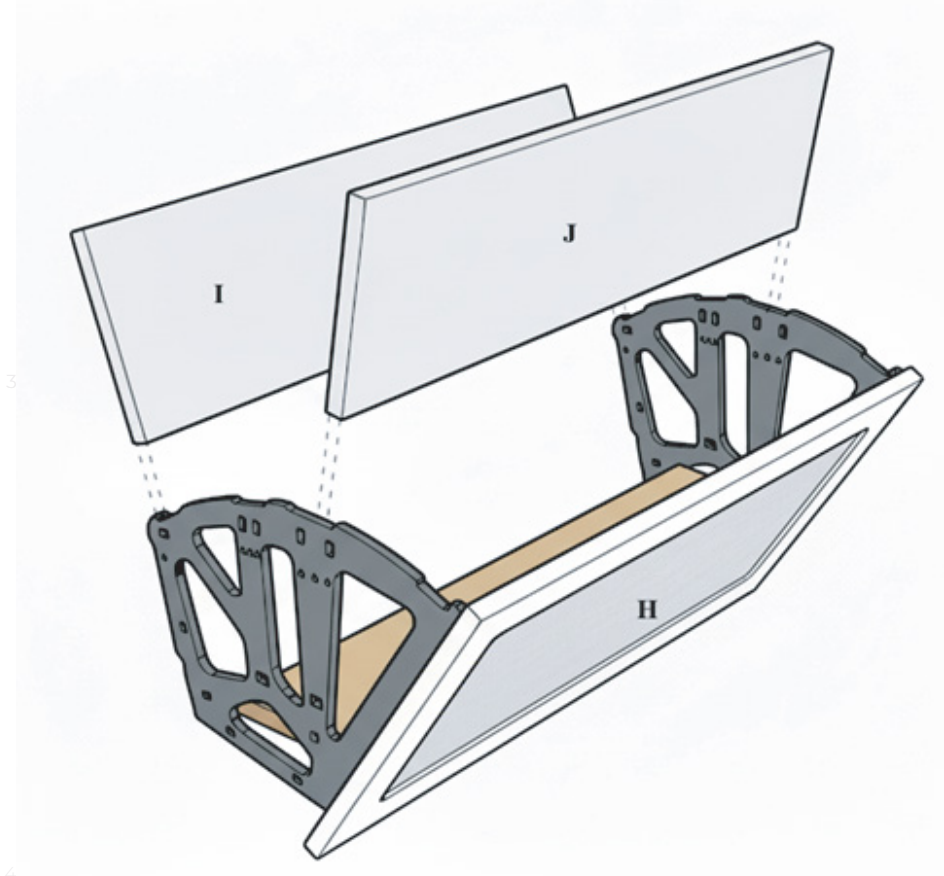

Step 6: Insert Front Panels

1. Insert Front Panel (Small) (I) and Front Panel (Large) (J) into the basket frame.
2. Push panels down until they sit fully in place.

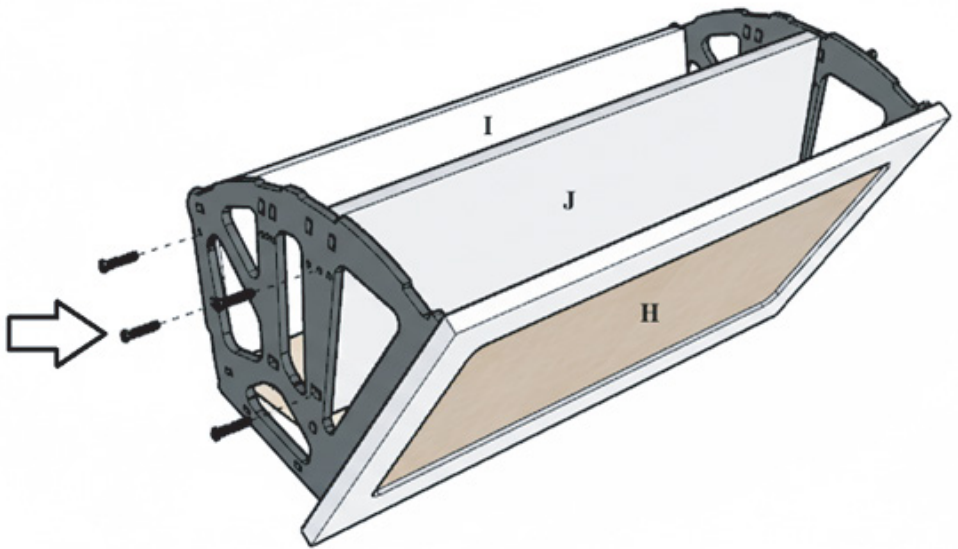

4

Step 7: Fix Front Panels (I & J) with Screws

1. Position Front Panel (Small) (I) and Front Panel (Large) (J) on the basket frame.
2. Align the screw holes properly.
3. Fix both panels using 16 mm screws (Item A).
4. Tighten screws firmly using a screwdriver.

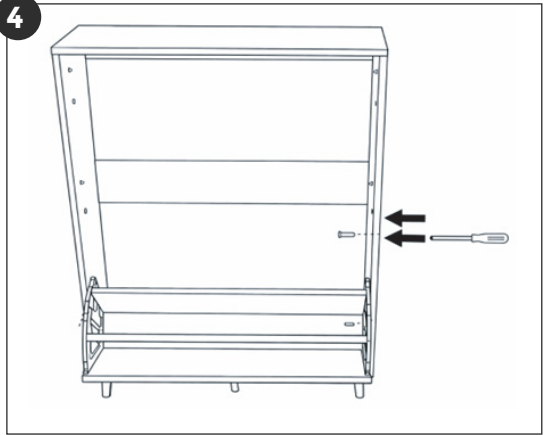
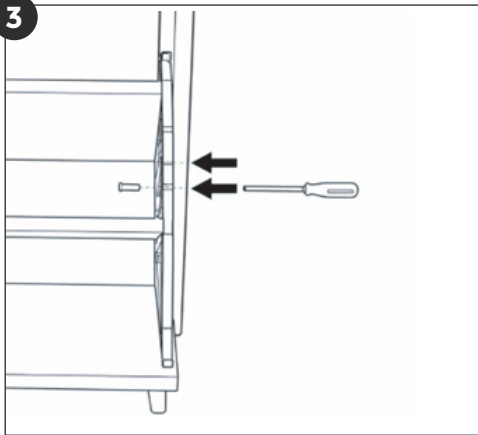
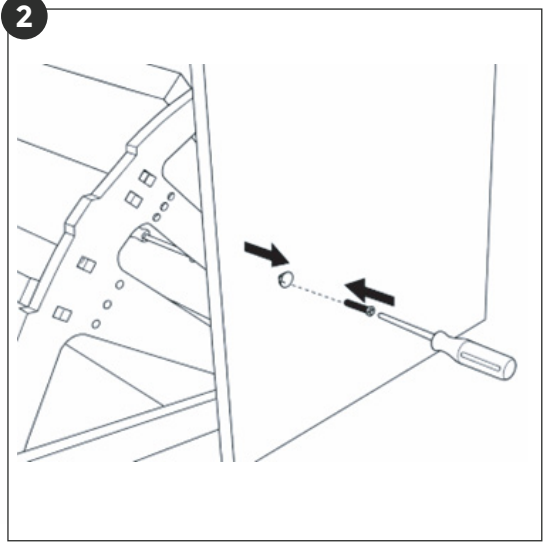
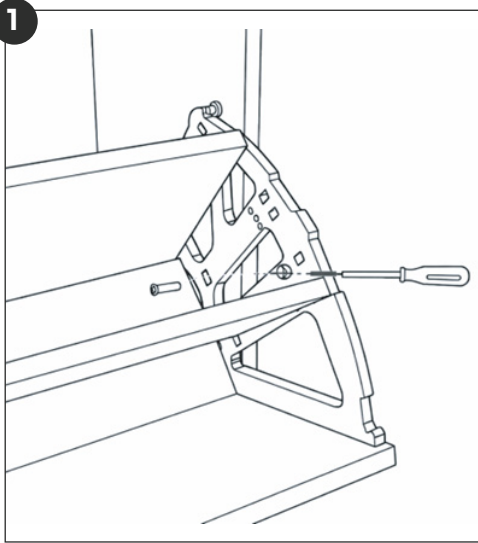

Step 8 : : Fix Basket Assembly to Cabinet

1. Slide the assembled basket unit into the cabinet.
2. Align the basket frame with the cabinet side holes.
3. Fix the basket using Cabinet Connectors (Item J).
4. Tighten securely using a screwdriver to lock the basket in place.

1

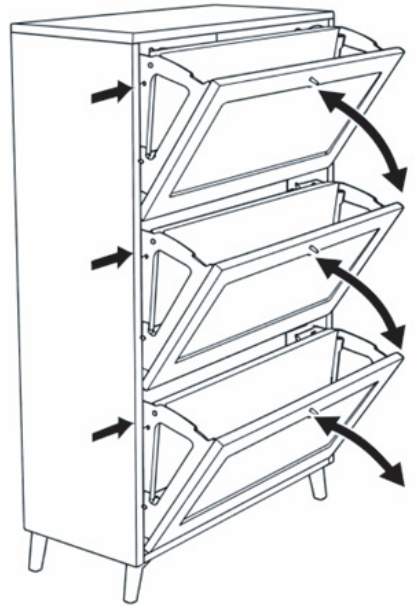
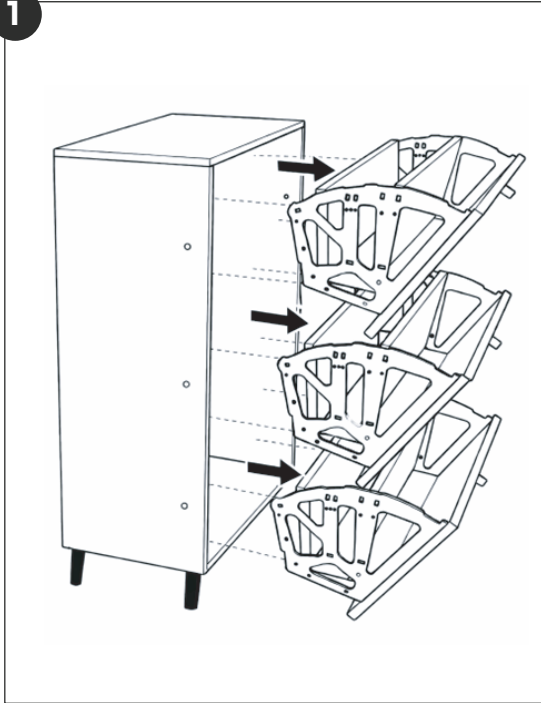

Step 9: Install Remaining Basket Assemblies

1. Repeat Step 8 for the remaining basket units.
2. Slide each basket into its respective position.
3. Fix each basket to the cabinet using Cabinet Connectors (Item J).
4. Tighten all connectors securely using a screwdriver.
5. Check that all baskets tilt/open smoothly.

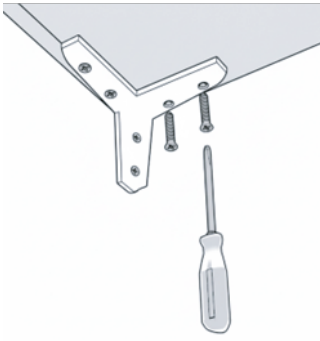

Step 10: Fix Bottom Support Legs

1. Turn the cabinet carefully to access the bottom.
2. Fix T Type Legs (Item G) at all four bottom corners.
3. Secure the legs using 19 mm screws (Item B).
4. Tighten all screws firmly using a screwdriver.
5. Place the cabinet upright and ensure it stands stable on a flat surface.

KANSO



AFTER SALES SUPPORT

+91 805 099 3344

www.interiorcompany.com

INTERIOR
C O M P A N Y
— By Square Yards —